

POS.	COD./KOD.	NOTE/MERKE/NOTES/NOTA/ NOTAS/ANMÄRKNINGAR
1	5.18.17.82	
2	5.13.04.62	
3	7.13.06.29	
4	5.87.10.84	
5	5.18.29.12	
6	5.18.29.11	
7	0.42.06.67	
8	0.84.00.35	
9	5.10.03.45	
10	0.12.01.05	
11	0.10.01.05	
12	5.08.10.00	
13	5.04.28.24	
14	5.15.20.75	
15	5.18.29.14	
16	0.53.62.01	
17	5.02.43.03	
18	5.05.01.40	
19	0.80.26.22	
20	7.82.01.26	
21	5.05.01.39	
22	0.33.04.26	
23	0.10.01.05	
24	5.15.35.04	
25	5.22.10.21	
26	0.10.01.04	
27	5.18.10.03	
28		
29	5.18.25.62	
30	5.18.17.84	
31	5.10.03.36	
32	5.19.03.10	
33	0.15.10.40	
34	7.01.36.36	
35	5.18.28.83	
36	0.10.01.06	

POS.	COD./KOD.	NOTE/MERKE/NOTES/NOTA/ NOTAS/ANMÄRKNINGAR
37	3.27.85.40	
38	0.12.01.08	
39	5.12.06.72	
40	0.10.70.12	
41	5.13.08.83	
42	5.18.17.81	
43	0.40.06.03	
44	0.33.05.10	
45	5.12.06.73	
46	0.22.11.06	
47	5.17.10.72	
48	0.15.50.10	
49	0.53.62.03	
50	0.10.61.16	
51	5.12.40.85	
52	5.17.00.03	
53	5.08.01.63	
54	5.04.28.23	
55	5.19.03.11	
56	0.33.05.20	
57		
58	0.15.14.11	
59	0.42.07.73	
60	5.08.01.60	
61	0.33.06.50	
62	0.12.01.06	
63	5.18.30.84	
64	5.13.08.82	
65	7.13.06.21	
66	0.31.06.45	
67	5.18.28.82	
68	0.33.05.25	
69	5.08.01.62	
70	0.10.70.13	
71	5.10.03.37	
72	7.13.06.48	

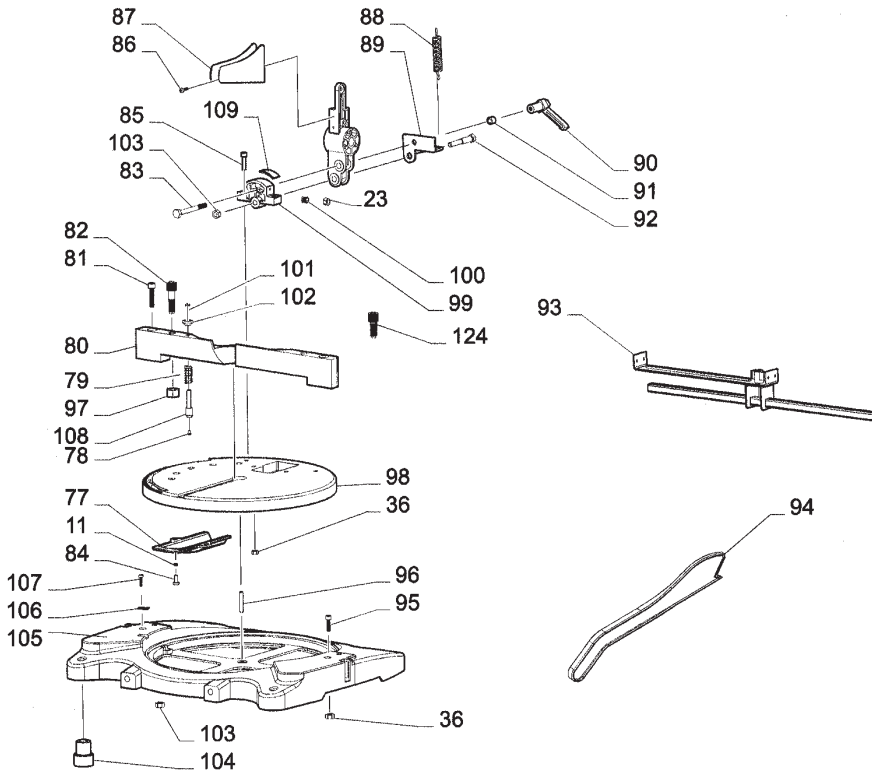

POS.	COD./KOD.	NOTE/MERKE/NOTES/NOTA/ NOTAS/ANMÄRKNINGAR
73	0.15.11.48	
74	0.10.01.05	
75	5.12.40.84	
76	7.13.06.30	
77	5.18.17.80	
78	5.15.90.13	
79	5.08.01.61	
80	5.13.09.17	
81	0.32.08.35	
82	5.10.03.39	
83	0.31.08.80	
84	0.33.05.13	
85	0.32.06.25	
86	0.33.04.06	
87	5.18.17.83	
88	5.08.10.33	
89	5.13.80.11	
90	0.14.70.19	
91	5.12.06.74	
92	5.10.03.38	
93	7.13.06.26	
94	0.14.20.02	
95	0.33.06.16	
96	5.17.10.74	
97	0.10.01.12	
98	5.13.79.79	
99	5.13.08.81	
100	0.41.05.09	
101	0.33.04.12	
102	5.14.00.56	
103	0.10.01.08	
104	5.13.79.80	
105	5.13.37.20	
106	5.15.95.19	
107	0.33.04.08	
108	5.17.05.37	
109	5.40.22.28	
110		
111	0.33.04.10	
112	0.15.15.12	
113	5.11.20.31	
114	5.18.29.13	
115		
116		
117	5.15.45.00	
118	0.88.20.12	
119		
120	0.33.04.10	
121	0.88.20.11	
122	5.87.10.83	
123	0.12.01.05	
124	5.10.03.44	