

ELECTRIC TOOL PARTS LIST

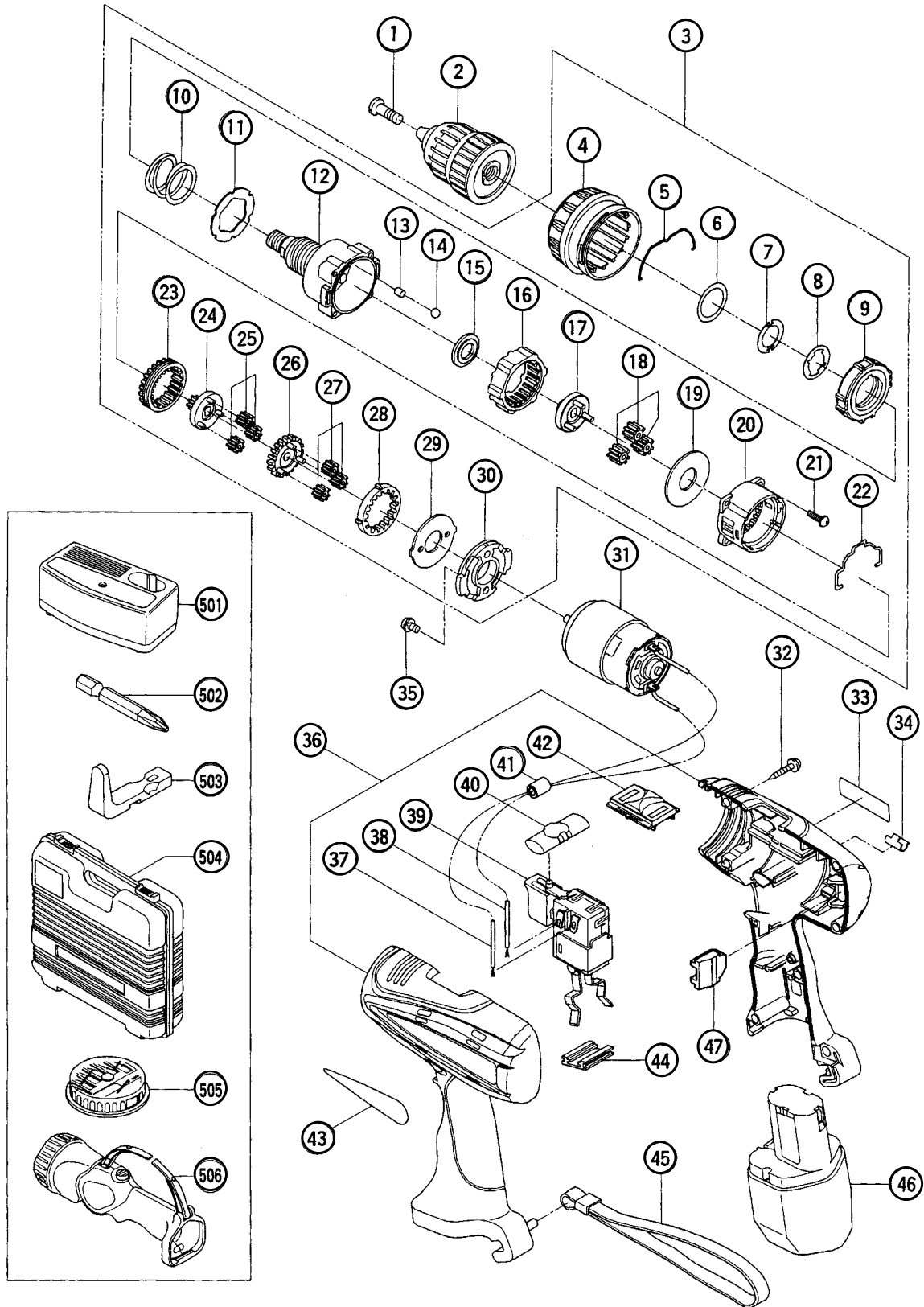

■ CORDLESS IMPACT DRILL
Model DV 12DV

2001·5·10
(E1)



PARTS

DV 12DV

ITEM NO.	CODE NO.	DESCRIPTION	NO. USED	REMARKS
1	311-959	SPECIAL SCREW (LEFT HAND) M6X23	1	
2	310-154	DRILL CHUCK 10VLR-N (W/O CHUCK WRENCH)	1	
3	319-959	GEAR BOX ASS'Y	1	INCLUD.4-30
4	319-963	CAP	1	
5	319-754	CLICK SPRING	1	
6	320-088	O-RING	1	
7	320-089	LOCK WASHER	1	
8	320-090	SWITCH PLATE	1	
9	319-743	NUT	1	
10	319-742	SPRING	1	
11	319-741	THRUST WASHER	1	
12	319-960	FRONT CASE	1	
13	319-744	ROLLER	6	
14	306-936	STEEL BALL D5	6	
15	319-746	SPACER WASHER	1	
16	319-745	RING GEAR	1	
17	319-747	CARRIER	1	
18	319-769	PLANET GEAR (C) SET (3 PCS.)	3	
19	312-704	WASHER (A)	1	
20	319-748	REAR CASE	1	
21	320-087	SCREW SET M3X12 (4 PCS.)	4	
22	319-753	SHIFT ARM	1	
23	319-750	SLIDE RING GEAR	1	
24	319-749	PINION (C)	1	
25	319-768	PLANET GEAR (B) SET (3 PCS.)	3	
26	319-751	PINION (B)	1	
27	319-767	PLANET GEAR (A) SET (3 PCS.)	3	
28	319-752	FIRST RING GEAR	1	
29	312-716	WASHER (B)	1	
30	316-955	MOTOR SPACER	1	
31	319-966	MOTOR	1	
32	313-687	TAPPING SCREW (W/FLANGE) D3X16 (BLACK)	7	
* 33		NAME PLATE	1	
34	318-237	BIT HOLDER	1	
35	317-333	MACHINE SCREW (W/SP. WASHER) M4X6	2	
36	319-965	HOUSING (A).(B) SET	1	
* 37	319-759	INTERNAL WIRE (BLACK) 100L	1	
* 37	320-133	INTERNAL WIRE (BLACK) 195L	1	FOR GBR,FRG,NOR,SWE,DEN
* 38	319-758	INTERNAL WIRE (RED) 130L	1	
* 38	320-132	INTERNAL WIRE (RED) 185L	1	FOR GBR,FRG,NOR,SWE,DEN
39	318-245	DC-SPEED CONTROL SWITCH	1	
40	319-760	PUSHING BUTTON	1	
* 41	318-247	FERRITE CORE	1	FOR GBR,FRG,NOR,SWE,DEN
42	318-234	SHIFT KNOB	1	
43		HITACHI LABEL	1	
44	315-141	TERMINAL SUPPORT (A)	1	
45	306-952	STRAP (BLACK)	1	
* 46	318-241	BATTERY FEB 12S (W/ENGLISH N.P)	3	
* 46	318-240	BATTERY FEB 12S (W/ENGLISH N.P)	2	FOR USA,CAN
* 46	318-239	BATTERY FEB 12S (W/ENGLISH N.P)	2	FOR NZL,SAF
* 47	320-131	CORE PROTECTOR	1	FOR GBR,FRG,NOR,SWE,DEN

* ALTERNATIVE PARTS